

COMLINE

Part number CCM001

PSA DV5 Assembled Camshaft Module



This Camshaft Module with the latest generation OXICOAT® 8mm pitch timing chain, will retro fit any engines fitted with 8mm or the earlier 7mm pitch chain. Making it suitable for all 1.5d DV5 variants, regardless of vehicle brand (Citroen, DS, Fiat, Ford, Opel, Peugeot, Toyota & Vauxhall) or production year.

- Pre-assembled, timed & pre-lubed camshaft module **saves up to 1.5hr labour time, reducing workshop costs and increasing productivity.**
- Following Comline's timing chain kit programme, **best practise information** regarding regular 10,000km oil & filter changes is printed in multiple languages on the inside of the box lid.
- To ensure hassle free installation **the module comes with all the required gaskets, seals, Comline RTV silicon & Comline pre-lube oil** to complete the task.
- Sticking to our "Complete Solution" ethos **Comline is the only company to include the vacuum pump profile gaskets with the module.** Providing the installer a hassle-free repair solution.

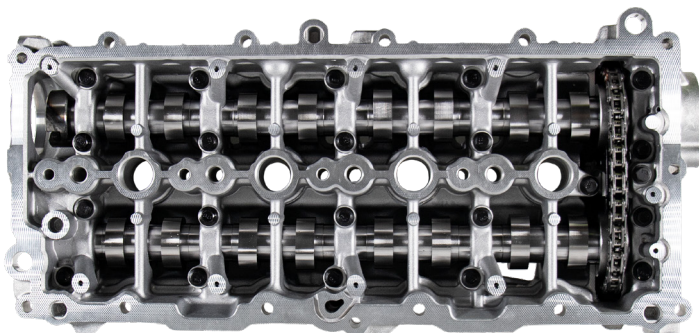

CCM001 reverse view



The CCM001 **packaging has been designed to assist the installer**. Full colour schematics show the kit bill of materials; torque values in Newton-meters (NM), the tightening sequence, the position and thickness of the RTV silicon bead needed to mount the module on to the cylinder head.

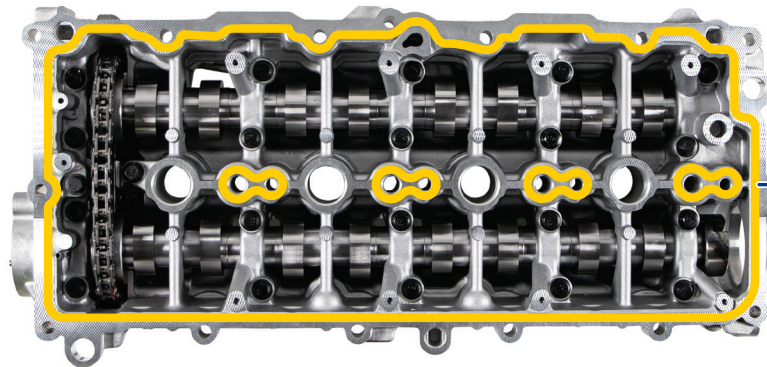

SILICON BEAD

1.5-2.5 MM

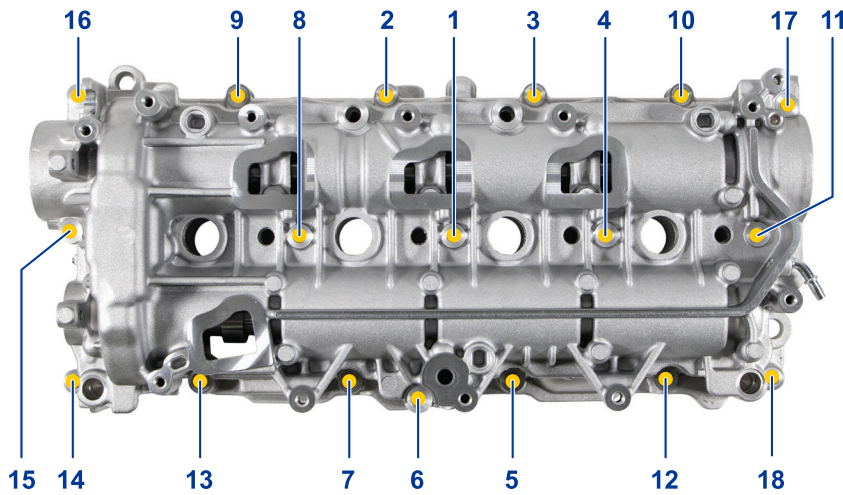

SEQUENCE
1-18

STAGE #1 = 3 NM
STAGE #2 = 10 NM

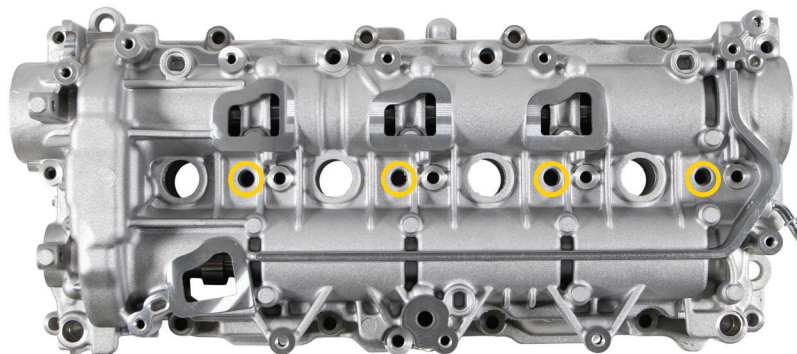

INJECTOR BOLTS

STAGE #1 = 10 NM
STAGE #2 = +90°

Critical Pre-Assembly Cleaning

During transportation the light oil used to lubricate the camshafts and chain mechanism during assembly, may have migrated to the cylinder head contact surface.

Using a lint free cloth with an Aluminium safe degreaser, be sure to clean all contact surfaces thoroughly before applying the Comline RTV silicon.